



▲ Willow

# Fortus Square Foot™

Retaining Wall System

*The Segmental Retaining Wall.....REIMAGINED*

# Fortus Square Foot™ - The Retaining Wall.....**REIMAGINED**

---

The Fortus Square Foot™ system redefines the way retaining walls are designed and built. Ideal for everything from residential landscaping to commercial projects, Fortus Square Foot's beautiful and distinctive color blends are unsurpassed in the industry and feature a perfect combination of beauty and strength. Bring your dreams to reality through Fortus Square Foot's maximum layout creativity when building curves, corners and angles due to its patented SecureLug™ Connection System. The Fortus Square Foot™ system combines durable, precast concrete with incredible ease of installation. When stacked and filled with aggregate, the lightweight and easy to handle Fortus Square Foot™ units interlock, providing high shear resistance and excellent connection strength to geosynthetic reinforcement, if required. For value, beauty, durability and ease of construction, your best choice is the Fortus Square Foot™ Retaining Wall System by LibertyStone™ Hardscaping Systems.



- Ultra-light weight for improved shipping and handling
- SecureLug™ Connection System allows for set-back wall installation
- Recessed “hand-holds” allow for the unit to be installed with incredible ease
- Increased vertical drainage through the units
- Strong and reliable connection between units and geosynthetic reinforcement

## Fortus Square Foot™ - SecureLug™ Connection System

---

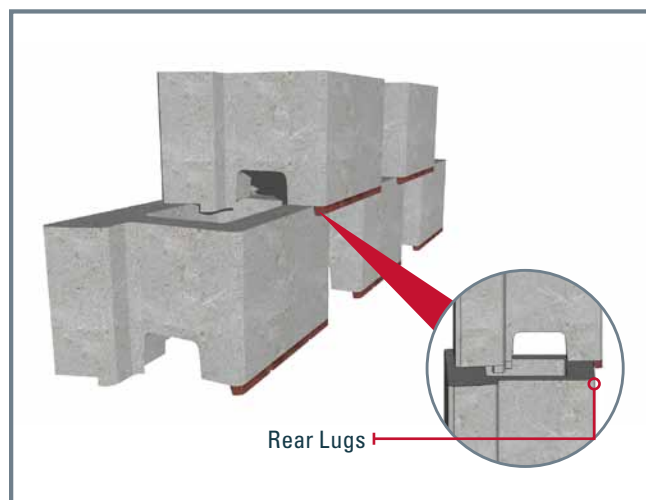

**USE REAR LUGS FOR TYPICAL SETBACK WALLS**



▲ Chestnut

Fortus Square Foot™ has been thoroughly tested for connection and strength in accordance with the design methodology promoted by the National Concrete Masonry Association (NCMA). Fortus Square Foot's patented SecureLug™ Connection System, when combined with gravel infill and geosynthetic reinforcement creates a strong, long lasting retaining wall. Fortus Square Foot™ can be built with a standard set-back, through the use of its segmented rear lugs, allowing for significant lateral movement without losing the connection interlock. Fortus Square Foot™ walls flex with seismic pressures and resist weathering. The hollow core of each unit provides excellent drainage, reducing the buildup of hydrostatic pressure. The light weight Fortus Square Foot™ unit does not require the use of expensive pins or clips and promotes layout flexibility, while saving time and expense during installation.

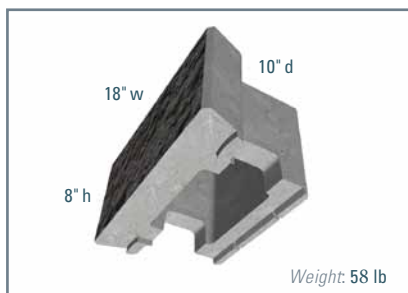

**STRAIGHT FACE**

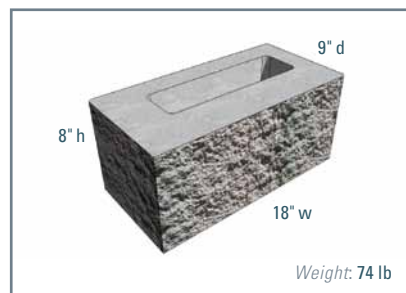

**90° CORNER**



**CAP UNIT**

# Fortus Square Foot™

Retaining Wall System

## Straight Face Colors



**WILLOW**



**WEST MOUNTAIN**



**CHESTNUT**



**DESERT**

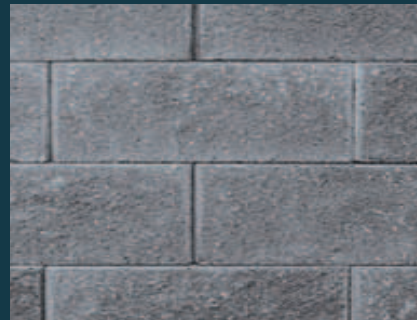

**MIDNIGHT**

LibertyStone™ Hardscaping Systems manufactures the Fortus Square Foot™ Retaining Wall System with some of the most beautiful and distinctive color blends in the industry. The Fortus Square Foot™ system has been designed to accommodate nearly every type of retaining wall application. Photos of our walls portrayed in this guide are approximate representations. Exact colors and appearance may vary as our products are made from 100% natural aggregates. We recommend that you make your selections from actual product samples available from your local LibertyStone™ dealer.

© Copyright LibertyStone™ Hardscaping Systems

FSFRWS-BR-032017

## Fortus Square Foot™ Marketing Materials

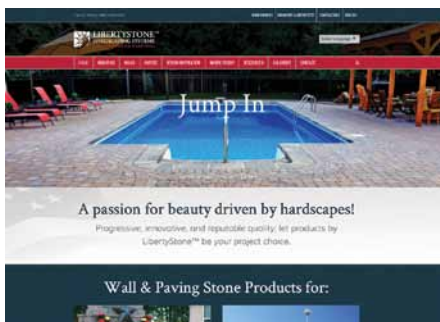

**LibertyStone™ Website**

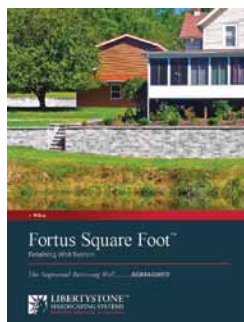

**General Brochures**

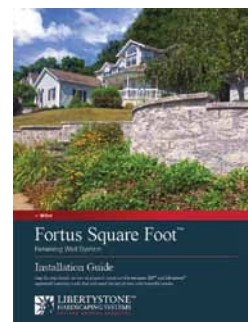

**Installation Guide**



**LibertyStone™ Catalog**



If you require more information on the Fortus™ Square Foot Retaining Wall System please visit LibertyStone online.

[www.liberty-stone.net](http://www.liberty-stone.net)